

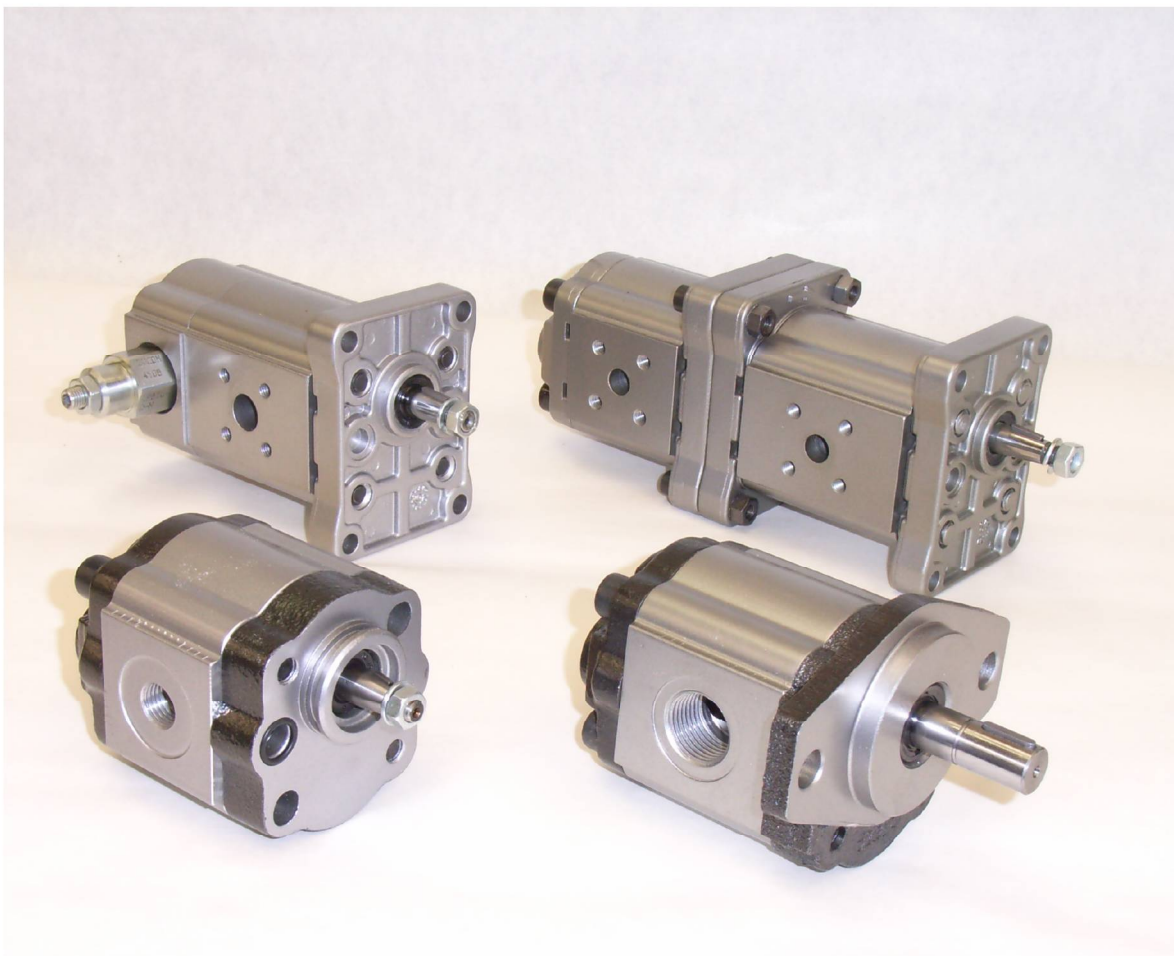

POMPE E MOTORI IN ALLUMINIO SERIE Z1
ALUMINIUM PUMPS AND MOTORS Z1 SERIES



Caratteristiche principali

- Coperchi in ghisa e in alluminio
- Possibilità di funzionare ad alte pressioni: fino a 300 bar di pressione massima in funzionamento continuo.
- Compensazione assiale per il recupero dei giochi
- Alto rendimento volumetrico: 95% medio.
- Ampia disponibilità di cilindrata: 0.8 -1.1-1.6-2.1-2.6-3.2-3.7-4.2-4.8-5.5-6.2-7.8-8.8 -10.5 cm³/giro
- Corpo in alluminio estruso
- Progetto accurato del profilo del dente per avere una bassa rumorosità.
- Vasta gamma di flange, alberi e connessioni compatibili con i principali standard del mercato.
- Disponibilità di guarnizioni per alte temperature
- Pompe e motori unidirezionali
- Pompe e motori bidirezionali
- Possibilità di montaggio di pompe multiple sia nelle serie in alluminio che con altre serie in ghisa

Main Features

- *Cast iron and alloy covers*
- *High pressure option: up to 300 bar max. continuous pressure (4350 psi)*
- *Axial compensation achieved using pressure balanced bushing blocks.*
- *High volumetric efficiency: average 95%*
- *Wide range of capacities : 0.8 -1.1-1.6-2.1-2.6-3.2-3.7-4.2-4.8-5.5-6.2-7.8-8.8 -10.5 cm³/rev*
- *Extruded aluminium body*
- *Gear tooth profile accurately projected providing low noise operation.*
- *A wide variety of shafts, flanges and ports are available to meet specific application requirements.*
- *High-temperature seals available.*
- *Single rotational pumps and motors.*
- *Bi-rotational pumps and motors.*
- *Multiple pumps availability: tandem pumps are possible both in aluminium series and with other cast iron series*

CONDIZIONI PER L'UTILIZZO DELLE POMPE E MOTORI "Z1"

CONDITIONS OF USE FOR PUMPS AND MOTORS "Z1"

Nell'utilizzo della pompa evitare carichi radiali e assiali sull'albero.

Il giunto di trascinamento deve compensare eventuali errori di allineamento , deve essere di tipo elastico oppure di tipo Oldham.

Per un corretto funzionamento e una lunga durata della pompa, osservare i valori riportati nella tabella seguente.

Avoid radial and axial loads on the pump shaft during the use.

The pump must be in line with the P.T.O. to compensate misalignment errors, use flexible or "Oldham" coupling.

We recommend to read the specifications in this catalogue very carefully. This will help you in getting the best, in terms of working conditions and life, from gear pumps.

CONDIZIONI DI L'UTILIZZO
USE CONDITIONS

Fluidi idraulici <i>Hydraulic fluids</i>	Oli idraulici a base minerale (DIN 51524) Per utilizzo di fluidi non infiammabili come acqua e glicole , emulsione di olio in acqua, o esteri fosforici, contattare il nostro ufficio tecnico o commerciale <i>Mineral oil (DIN 51524)</i> <i>For use with fire resistant fluids like water glycol, water- oil emulsion and phosphate-esters, contact our technical or commercial office.</i>		
Pressione in aspirazione <i>Inlet pressure</i>	0.7 - 3 bar (Assoluti / Absolute) 10 - 44 psi (Assoluti / Absolute)		
Velocità olio nella linea di aspirazione <i>Oil speed on suction line</i>	0.5 ÷ 1.5 m/s		
Velocità olio nella linea di mandata <i>Oil speed on pressure line</i>	6 ÷ 10 m/s		
Temperatura olio <i>Oil temperature</i>	-10°C ÷ 80°C		
Viscosità olio <i>Oil viscosity</i>	20 ÷ 120 mm ² / s (Cst)		
Massima viscosità olio all'avvio <i>Max starting viscosity</i>	700 mm ² / s (Cst)		
Filtraggio olio <i>Oil filtration</i>	Pressione <i>Pressure</i>	< 200 bar	> 200 bar
	Classe di contaminazione NAS 1638 <i>Contamination class NAS 1638</i>	10	9
	Classe di contaminazione ISO 4406 <i>Contamination class ISO 4406</i>	19/16	18/15
	Rapporto β _x ≥ 75 Ratio β _x ≥ 75	25µm	10µm

FORMULE PER DIMENSIONAMENTO
DETERMINATION OF NOMINAL SIZE

PER POMPE
FOR PUMP

$$Q = \frac{V * \eta_v * n}{1000}$$

$$M = \frac{p * V}{62.8 * \eta_m}$$

$$P = \frac{p * Q}{600 * \eta_t}$$

PER MOTORI
FOR MOTOR

$$Q = \frac{V * n}{1000 * \eta_v}$$

$$M = \frac{p * V * \eta_m}{62.8}$$

$$P = \frac{p * Q * \eta_t}{600}$$

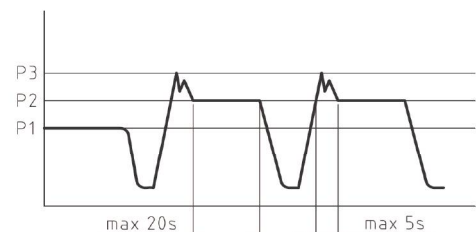

V [cm³]
 Q [l/min]
 p [bar]
 M [Nm]
 n [min⁻¹]
 P [Kw]

η_v = EFF vol. ≥ 95
 η_m = EFF mecc. ~ 0.85
 η_t = η_v * η_m. ~ 0.8

CARATTERISTICHE PRINCIPALI

MAIN CHARACTERISTICS

FLANGIA E COPERCHI IN ALLUMINIO / ALLOY COVER AND FLANGE

Tipo Type		08	11	16	21	26	32	37	42	48	55	62	78	88	105
Cilindrata Capacity	Cm ³ / giro Cm ³ / rev	0.80	1.08	1.59	2.09	2.59	3.15	3.68	4.19	4.79	5.49	6.2	7.81	8.82	10.5
P1 Pressione max continua Max working pressure	Bar	240	240	240	240	230	210	210	190	180	170	150	130	120	100
P2 Pressione intermittente Intermittent pressure	Bar	260	260	250	250	250	240	230	210	200	180	160	140	130	120
P3 Pressione max di picco Max peak pressure	Bar	280	280	280	280	280	270	260	240	230	210	190	170	160	130
Velocità max per pressione P1 Max speed for P1 pressure	Giri / min Rpm	6000	6000	6000	6000	5500	4500	4000	3800	3500	3500	3000	3000	3000	3000
Velocità max a vuoto Max speed without load	Giri / min Rpm	8000	8000	8000	8000	8000	7000	6000	5500	5000	4500	4500	4000	4000	4000
Velocità min. per pressione P1 Min speed for P1 pressure	Giri / min Rpm	1100	1100	950	800	700	600	500	450	400	400	400	400	400	400

FLANGIA E COPERCHI IN GHISA / CAST IRON COVER AND FLANGE

Tipo Type		08	11	16	21	26	32	37	42	48	55	62	78	88	105
Cilindrata Capacity	Cm ³ / giro Cm ³ / rev	0.80	1.08	1.59	2.09	2.59	3.15	3.68	4.19	4.79	5.49	6.2	7.81	8.82	10.5
P1 Pressione max continua Max working pressure	Bar	300	300	300	300	300	300	275	260	260	240	230	190	170	140
P2 Pressione intermittente Intermittent pressure	Bar	320	320	320	320	320	320	290	275	275	250	240	200	180	150
P3 Pressione max di picco Max peak pressure	Bar	350	350	350	350	350	350	310	290	290	270	260	220	200	170
Velocità max per pressione P1 Max speed for P1 pressure	Giri / min Rpm	8000	8000	8000	7000	5700	4700	4400	4000	3600	3400	3200	3000	3000	3000
Velocità max a vuoto Max speed without load	Giri / min Rpm	8000	8000	8000	8000	8000	7000	6000	5500	5000	4500	4500	4000	4000	4000
Velocità min. per pressione P1 Min speed for P1 pressure	Giri / min Rpm	1500	1200	1000	800	650	550	450	400	350	300	250	200	200	150

Per alberi tipo D, N, Q, P, S e R le prestazioni sono maggiori di quelle indicate in tabella. Per maggiori informazioni contattare il nostro ufficio tecnico.

The performance of pumps with shaft D, N, Q, P, S and R are higher than the above table. Please contact our technical office for more information.

Per pompe o motori bidirezionali , diminuire la pressione del 15%
With bidirectional pumps or motors , pressure is reduced by 15%

COMPONENTI
PARTS

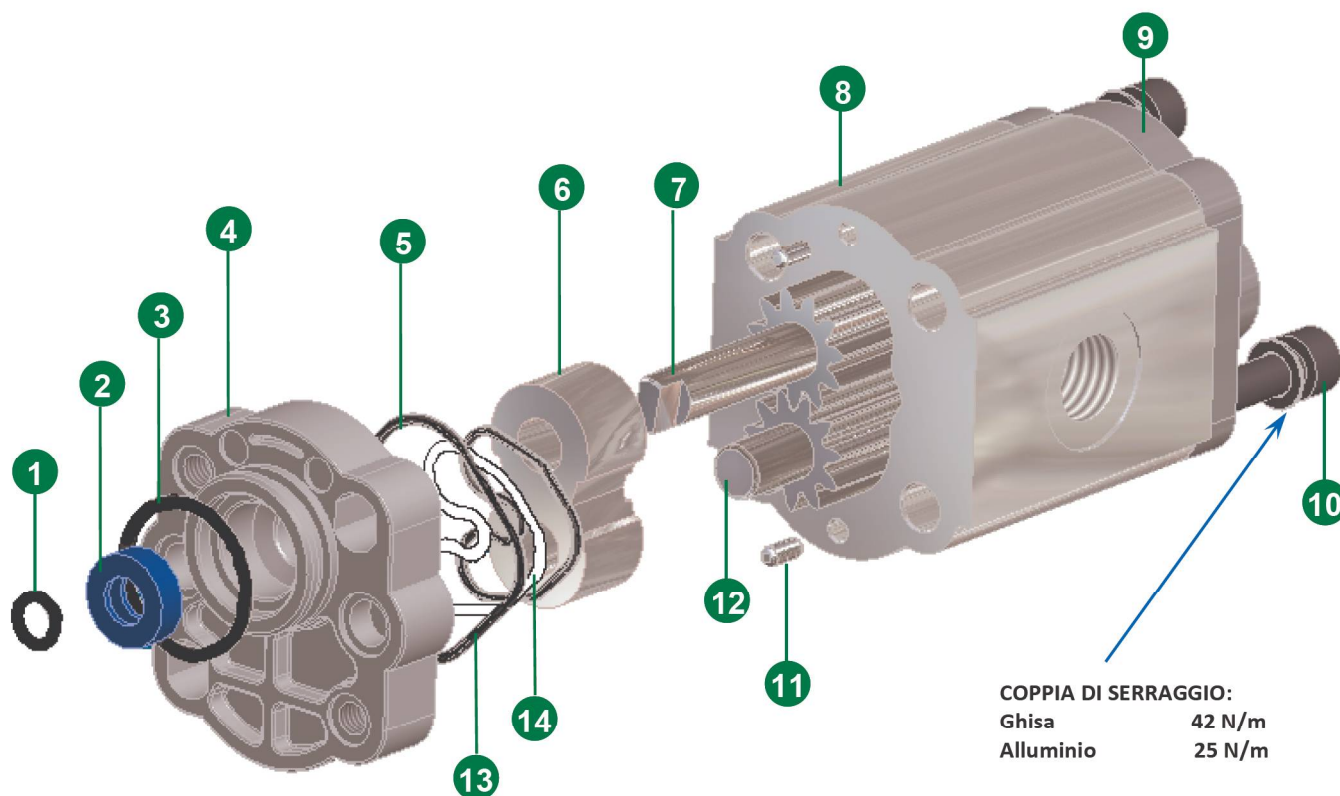

COPPIA DI SERRAGGIO:
Ghisa 42 N/m
Alluminio 25 N/m

TORQUE:
Cast iron 42 N/m
Aluminium 25 N/m

Rif.	Descrizione	Description	Qt.
1	OR Mandata	Outlet seal	1
2	Anello di tenuta	Rotary shaft seal	1
3	OR Flangia	Flange seal	1
4	Flangia	Front flange	1
5	Guarnizione sotto-coperchio	Under cover seal	2
6	Rasamento	Bushing block	2
7	Ingranaggio conduttore	Drive gear	1
8	Corpo	Housing	1
9	Coperchio	Cover	1
10	Vite	Bolt	2
11	Spina cilindrica	Pin	4
12	Ingranaggio condotto	Idle gear	1
13	Guarnizione di compensazione	Compensation seal	2
14	Antiestrusore	B-K seals	2

SENSO DI ROTAZIONE
ROTATION

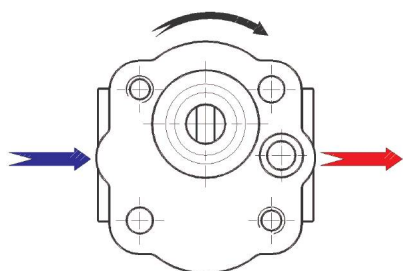

Rotazione destra <i>Clockwise rotation</i>	Codice <i>Code</i>	D
--	------------------------------	----------

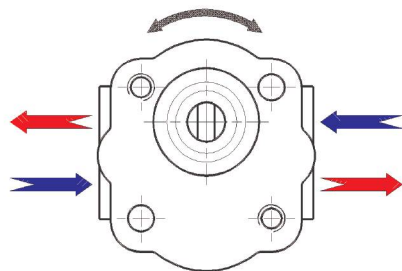

Rotazione bidirezionale drenaggio esterno <i>Bidirectional rotation with external drain</i>	Codice <i>Code</i>	R*
Rotazione bidirezionale drenaggio interno <i>Bidirectional rotation with internal drain</i>	Codice <i>Code</i>	Y

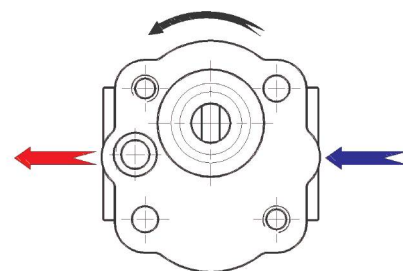

Rotazione sinistra <i>Anti-Clockwise rot.</i>	Codice <i>Code</i>	S
---	------------------------------	----------

Il senso di rotazione, è indicato con una freccia sul corpo della pompa .
Rotation, is indicated by an arrow on the body of the pump.

GUARNIZIONI PER ALBERI
SHAFT SEALS

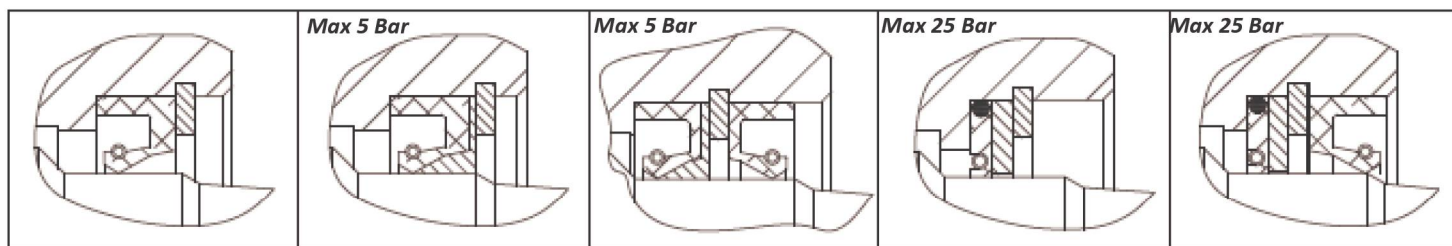

Codice <i>Code</i>	N	NBR
	V	VITON

Codice <i>Code</i>	R*	NBR
	RV	VITON

Codice <i>Code</i>	N2	NBR
	V2	VITON

Codice <i>Code</i>	B	//
------------------------------	----------	-----------

Codice <i>Code</i>	BN	NBR
	BV	VITON

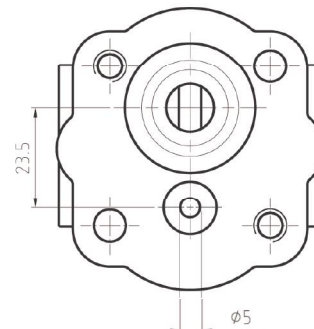
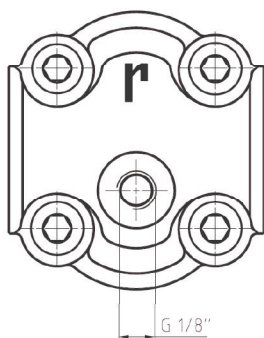

Drenaggio posteriore per pompe o motori reversibili <i>Rear drain for bidirectional pumps or motors</i>	R*
---	-----------

Drenaggio anteriore per pompe o motori reversibili <i>Front drain for pumps or motors</i>	R1
---	-----------

* il codice "R" comprende rotazione bidirezionale, paraolio rinforzato 5 bar e drenaggio posteriore
Code "R" includes bidirectional rotation, reinforced shaft seal 5 bar and rear drain

FLANGE
FLANGES

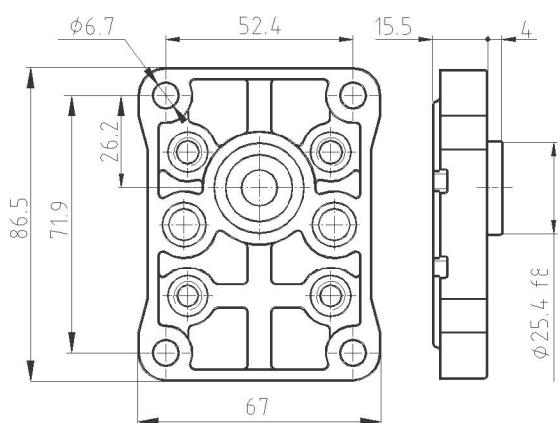

CODICE <i>CODE</i>	A	0	4
------------------------------	----------	----------	----------

NOTA : Materiale Alluminio
NOTE : Material Alloy

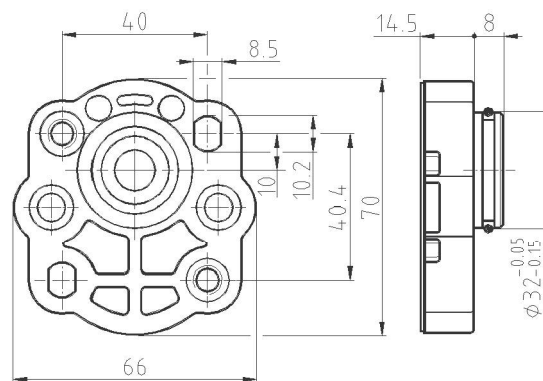

CODICE <i>CODE</i>	B	0	1
------------------------------	----------	----------	----------

NOTA : Materiale Alluminio
NOTE : Material Alloy

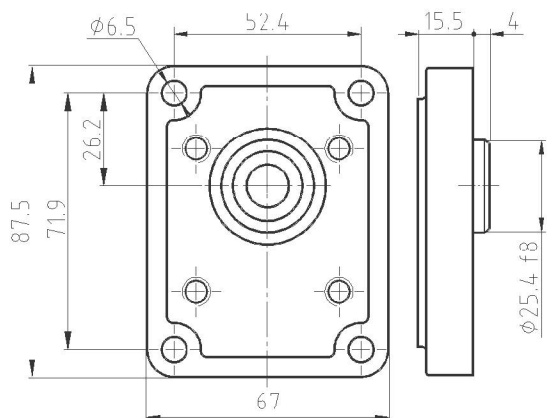

CODICE <i>CODE</i>	A	G	4
------------------------------	----------	----------	----------

NOTA : Materiale Ghisa
NOTE : Material cast iron

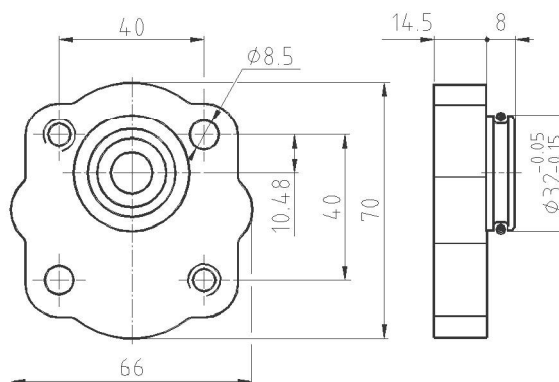

CODICE <i>CODE</i>	B	G	1
------------------------------	----------	----------	----------

NOTA : Materiale Ghisa
NOTE : Material cast iron

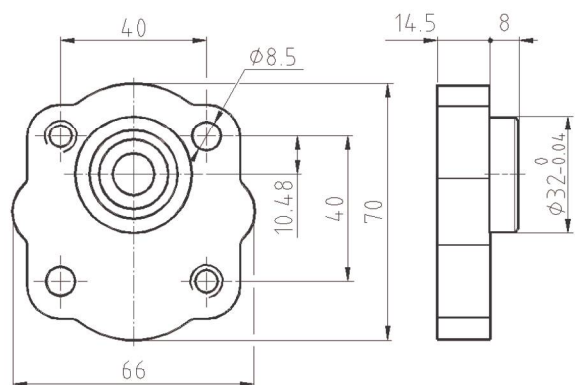

CODICE <i>CODE</i>	B	G	5
------------------------------	----------	----------	----------

NOTA : Materiale Ghisa
NOTE : Material cast iron

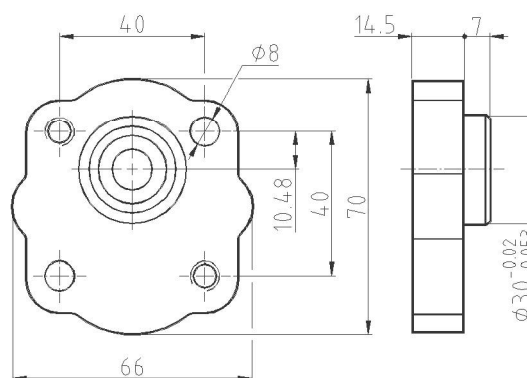

CODICE <i>CODE</i>	B	G	2
------------------------------	----------	----------	----------

NOTA : Materiale Ghisa
NOTE : Material cast iron

FLANGE
FLANGES

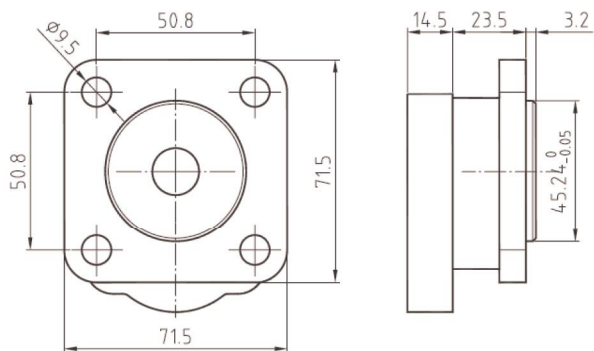

CODICE <i>CODE</i>	D	G	7
------------------------------	----------	----------	----------

NOTA : Materiale Ghisa
NOTE : Material cast iron

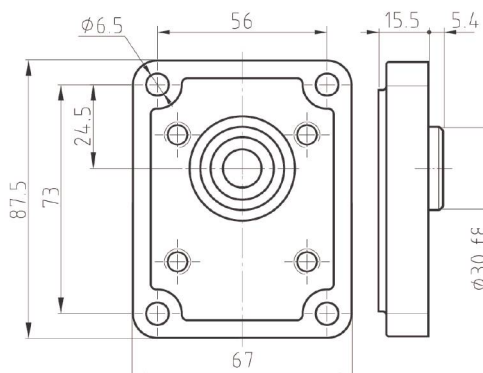

CODICE <i>CODE</i>	E	G	2
------------------------------	----------	----------	----------

NOTA : Materiale Ghisa
NOTE : Material cast iron

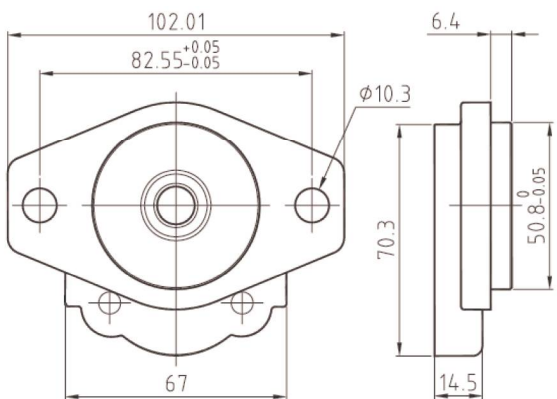

CODICE <i>CODE</i>	C	G	6
------------------------------	----------	----------	----------

NOTA : Materiale Ghisa
NOTE : Material cast iron

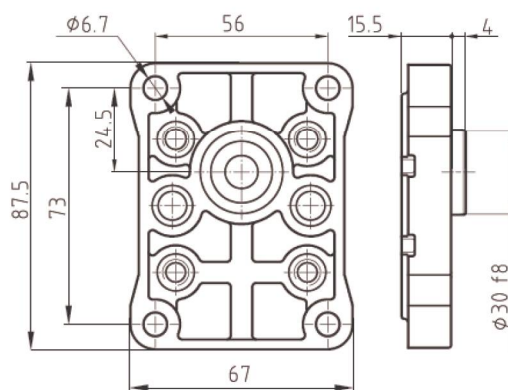

CODICE <i>CODE</i>	E	0	2
------------------------------	----------	----------	----------

NOTA : Materiale Alluminio
NOTE : Material Aluminium

ALBERI
SHAFTS

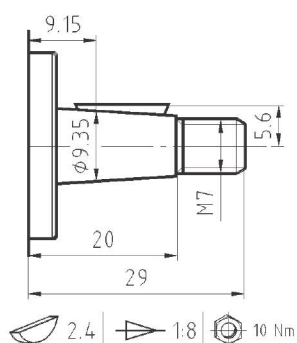

Coppia max 36 Nm
Max torque 36 Nm

CODICE / CODE	C		
PER FLANGIA / FOR FLANGE	A	G	4
	A	0	4

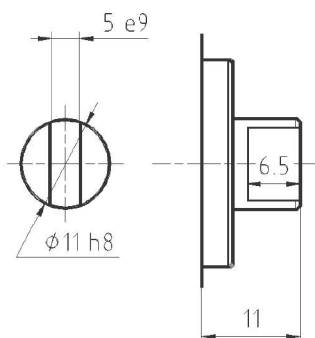

Coppia max 24 Nm
Max torque 24 Nm

CODICE / CODE	F		
PER FLANGIA / FOR FLANGE	A	G	4
	A	0	4

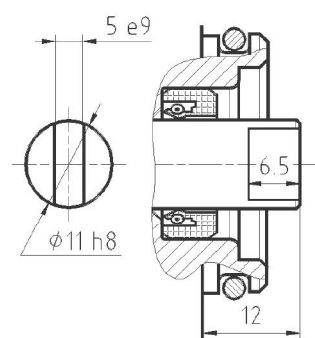

Coppia max 24 Nm
Max torque 24 Nm

CODICE / CODE	F		
PER FLANGIA / FOR FLANGE	B	G	1
	B	0	1

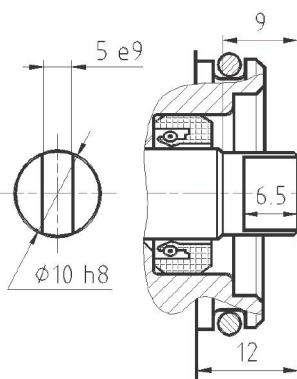

Coppia max 18 Nm
Max torque 18 Nm

CODICE / CODE	M		
PER FLANGIA / FOR FLANGE	B	G	1
	B	0	1

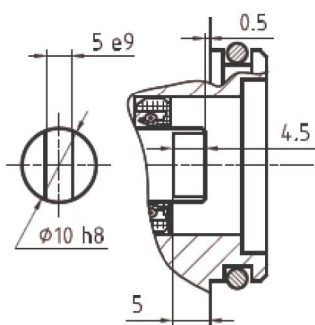

Coppia max 18 Nm
Max torque 18 Nm

CODICE / CODE	G		
PER FLANGIA / FOR FLANGE	B	G	1
	B	0	1

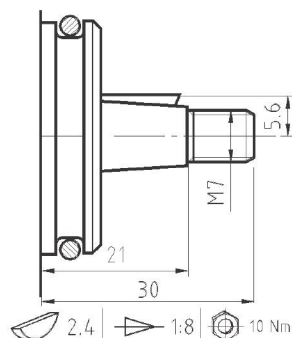

Coppia max 36 Nm
Max torque 36 Nm

CODICE / CODE	C		
PER FLANGIA / FOR FLANGE	B	G	1
	B	0	1

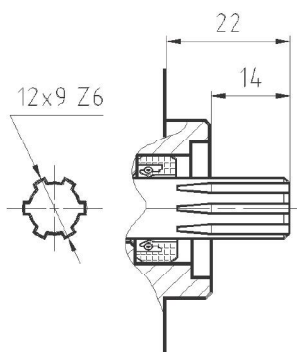

Coppia max 38 Nm
Max torque 38 Nm

CODICE / CODE	D		
PER FLANGIA / FOR FLANGE	B	G	5
	B	0	5

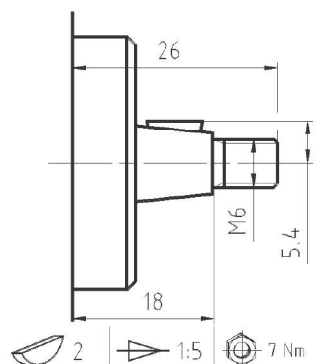

Coppia max 30 Nm
Max torque 30 Nm

CODICE / CODE	B		
PER FLANGIA / FOR FLANGE	B	G	5
	B	0	5

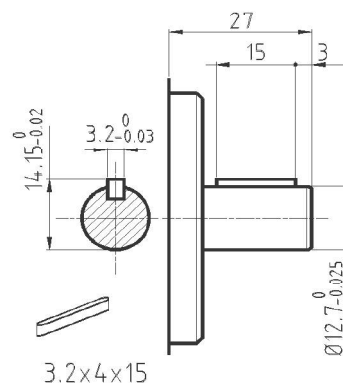

Coppia max 28 Nm
Max torque 28 Nm

CODICE / CODE	N		
PER FLANGIA / FOR FLANGE	C	G	6

ALBERI
SHAFTS

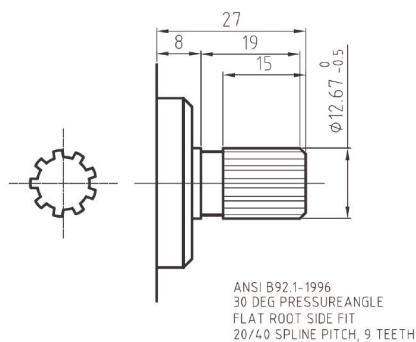

Coppia max 45 Nm
Max torque 45 Nm

CODICE / CODE	Q		
PER FLANGIA / FOR FLANGE	C	G	6

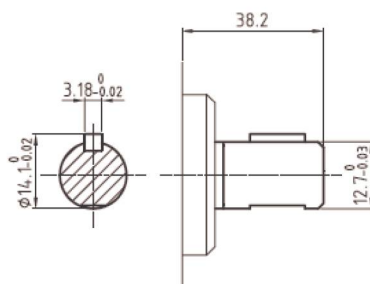

Coppia max 35 Nm
Max torque 35 Nm

CODICE / CODE	P		
PER FLANGIA / FOR FLANGE	D	G	7

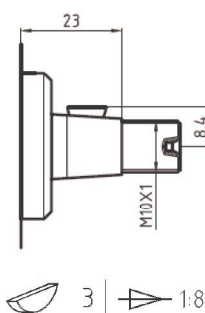

Coppia max 60 Nm *
Max torque 60 Nm

CODICE / CODE	S		
PER FLANGIA / FOR FLANGE	A	G	4
	A	0	4
	E	G	2

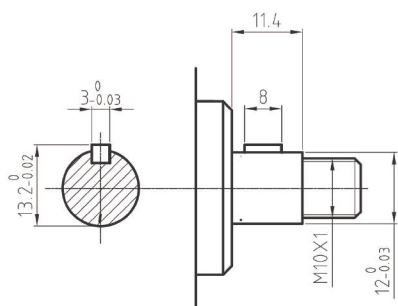

Coppia max 16 Nm
Max torque 16 Nm

CODICE / CODE	R		
PER FLANGIA / FOR FLANGE	A	G	4
	A	0	4

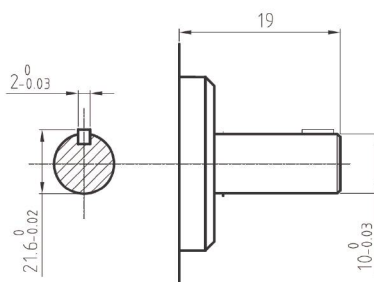

Coppia max 12 Nm
Max torque 12 Nm

CODICE / CODE	L		
PER FLANGIA / FOR FLANGE	A	G	4
	A	0	4

* per giunti motore/pompa consultare il nostro catalogo "Client Service" o richiedere informazioni al nostro ufficio commerciale.
For complete motor/pump coupling refer to our catalogue "Client Service" or ask more info to our sales department.

BOCCHIE DI ASPIRAZIONE E MANDATA INLET AND OUTLET PORTS

ASPIRAZIONE LATERALE SIDE INLET	MANDATA LATERALE SIDE OUTLET
------------------------------------	---------------------------------

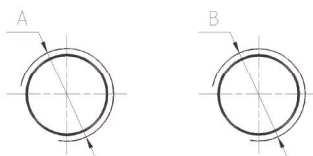

A	B	Codice Code
G 1/2	G 3/8	00
G 3/8	G 3/8	01
G 1/4	G 1/4	06
M18x1.5	M14x1.5	09
9/16-18UNF	9/16-18UNF	54
3/4-16UNF	9/16-18UNF	55

ASPIRAZIONE LATERALE SIDE INLET	MANDATA LATERALE SIDE OUTLET
------------------------------------	---------------------------------

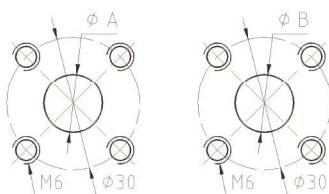

A	B	Codice Code
13	8	13
12	8	16
10	10	17
12	12	42

ASPIRAZIONE LATERALE SIDE INLET	MANDATA LATERALE SIDE OUTLET
------------------------------------	---------------------------------

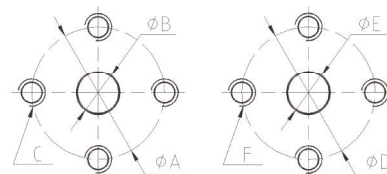

B	A	C	E	D	F	Codice Code
12	30	M6	12	30	M6	14
10	26	M5	10	26	M5	28

ASPIRAZIONE LATERALE SIDE INLET	MANDATA ANTERIORE FRONT OUTLET
------------------------------------	-----------------------------------

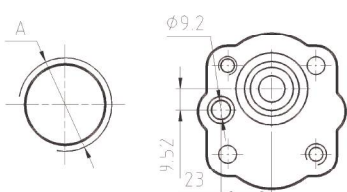

LA FIGURA MOSTRA UNA
POMPA SINISTRA

A	Codice Code
G 3/8	05
G 1/4	08

ASPIRAZIONE LATERALE SIDE INLET	MANDATA POSTERIORE REAR OUTLET
------------------------------------	-----------------------------------

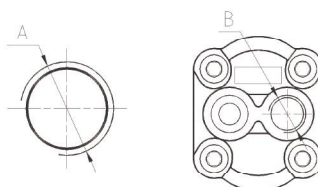

A	B	Codice Code
G 3/8	G 3/8	03
G 3/8	G 1/4	04

ASPIRAZIONE POSTERIORE REAR INLET	MANDATA POSTERIORE REAR OUTLET
--------------------------------------	-----------------------------------

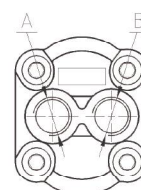

A	B	Codice Code
G 3/8	G 3/8	19
G 3/8	G 1/4	20

BOCCHIE DI ASPIRAZIONE E MANDATA

INLET AND OUTLET PORTS

ASPIRAZIONE LATERALE <i>SIDE INLET</i>	MANDATA ANTERIORE <i>FRONT OUTLET</i>
ASPIRAZIONE POSTERIORE <i>REAR INLET</i>	

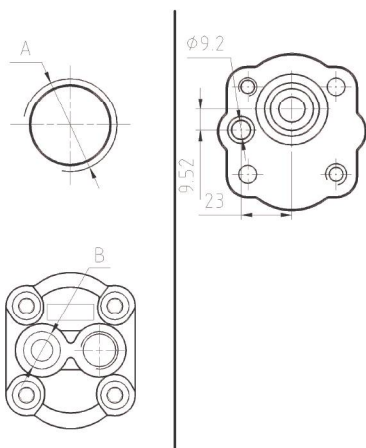

A	B	Codice Code
G 1/4	G 3/8	23
G 1/4	G 1/4	25
3/4-16UNF	G 3/8	39

ASPIRAZIONE LATERALE <i>SIDE INLET</i>	MANDATA LATERALE <i>SIDE OUTLET</i>
ASPIRAZIONE POSTERIORE <i>REAR INLET</i>	MANDATA POSTERIORE <i>REAR OUTLET</i>

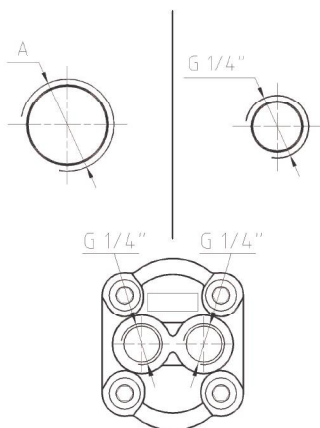

A	Codice Code
G 3/8	22
G 1/4	31

ASPIRAZIONE POSTERIORE <i>REAR INLET</i>	MANDATA ANTERIORE <i>FRONT OUTLET</i>
---	--

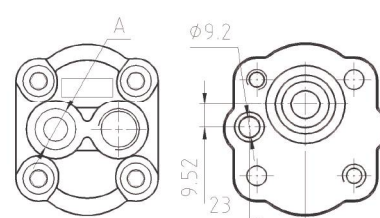

A	Codice Code
G 1/4	24
G 3/8	30

ASPIRAZIONE LATERALE <i>SIDE INLET</i>	MANDATA LATERALE <i>SIDE OUTLET</i>
	MANDATA POSTERIORE <i>REAR OUTLET</i>

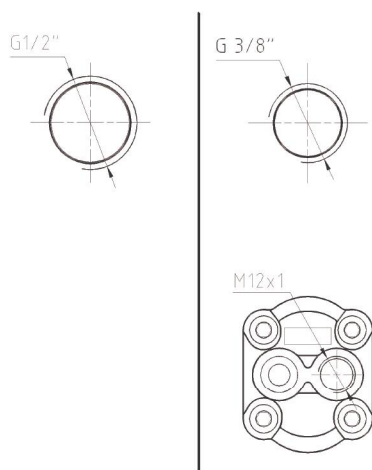

Codice Code	26
----------------	----

ASPIRAZIONE POSTERIORE <i>REAR INLET</i>	MANDATA LATERALE <i>SIDE OUTLET</i>
---	--

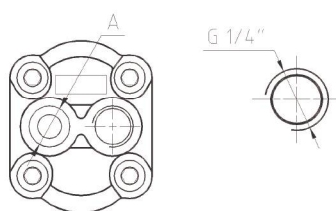

A	Codice Code
G 1/4	40
G 3/8	43

ASPIRAZIONE POSTERIORE <i>REAR INLET</i>	ASPIRAZIONE ANTERIORE <i>FRONT INLET</i>
MANDATA POSTERIORE <i>REAR OUTLET</i>	MANDATA ANTERIORE <i>FRONT OUTLET</i>

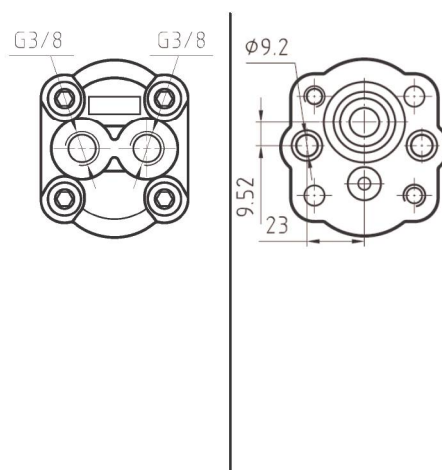

Codice Code	60
----------------	----

DIMENSIONI D'INGOMBRO
OVERALL DIMENSIONS

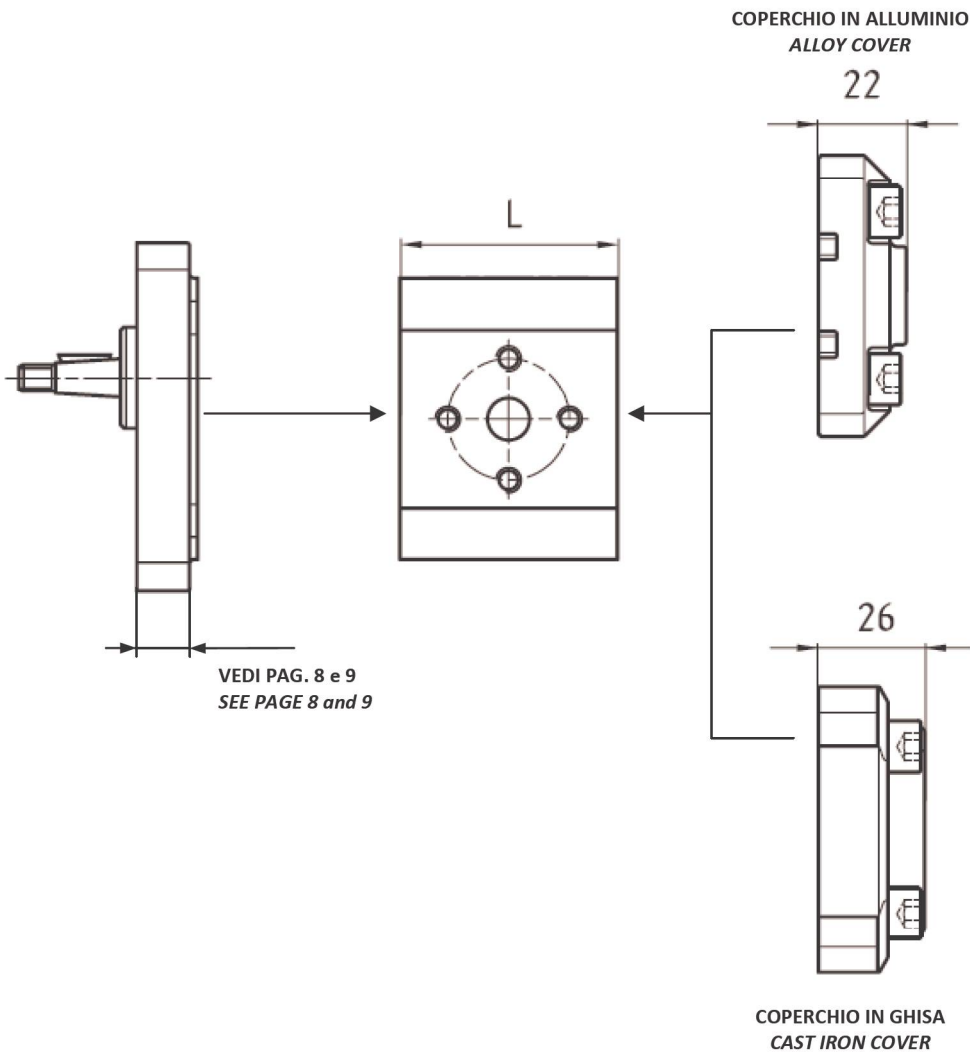

TIPO TYPE	L
08	37,4
11	38,3
16	40,3
21	42,3
26	44,3
32	46,5
37	48,6
42	50,6
48	53
55	55,8
62	58,6
78	65
88	69
105	82.3

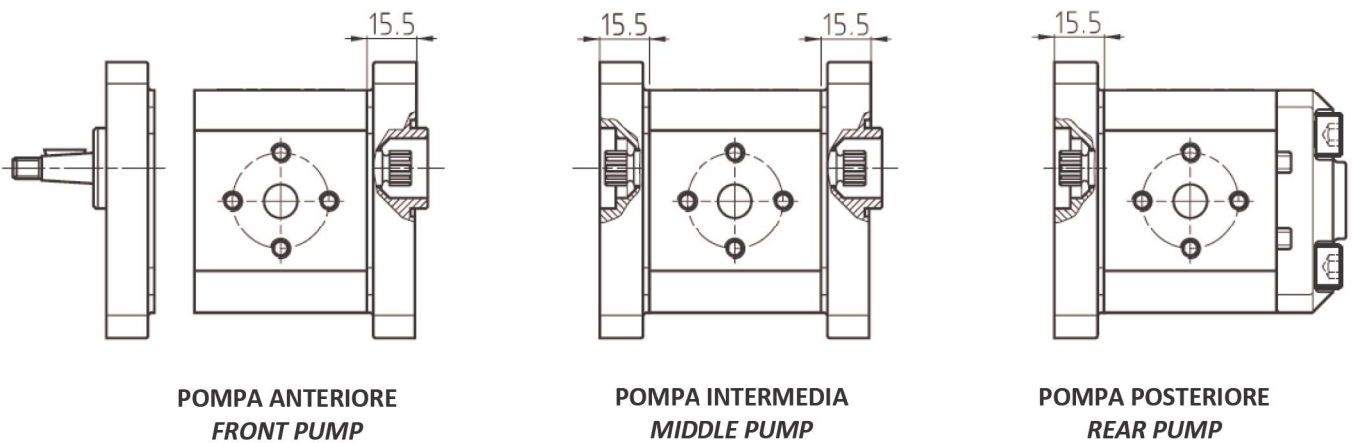

POMPE PREDISPOSTE TANDEM
PREASSEMBLED FOR TANDEM PUMPS

1

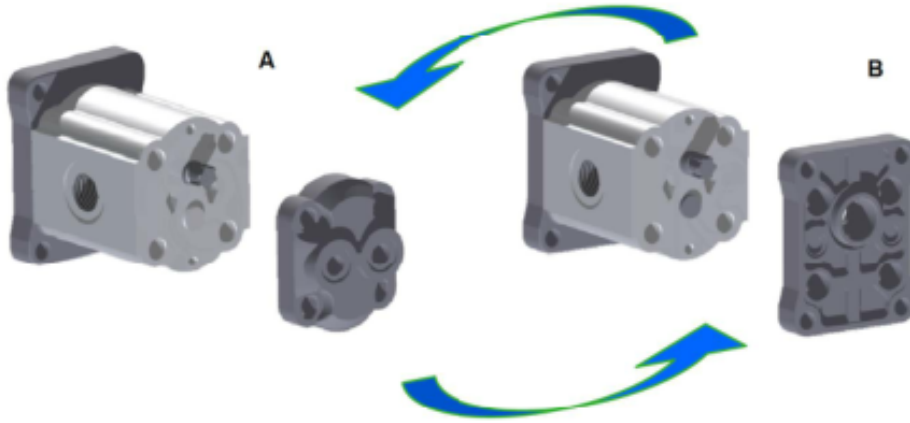

2

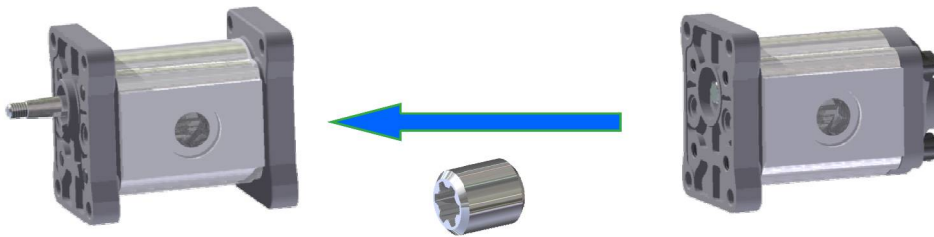

3



Sostituendo il coperchio posteriore della pompa predisposta tandem con il coperchio posteriore della pompa intermedia si evita di tenere a magazzino la pompa posteriore, eventualmente la pompa predisposta può essere utilizzata come pompa singola. Questa operazione deve essere effettuata da personale esperto e per motivi di sicurezza la pompa deve essere ri-collaudata.

The above system of assembling tandem pumps using a simple pump with the tandem gear and an intermediate pump, is available to reduce stocks. The pump with tandem gear can be used as single pump. This operation must be done by qualified staff only.

KIT DI MONTAGGIO DELLE UNITA' MULTIPLE Z1
ASSEMBLING KIT FOR MULTIPLE UNITS Z1

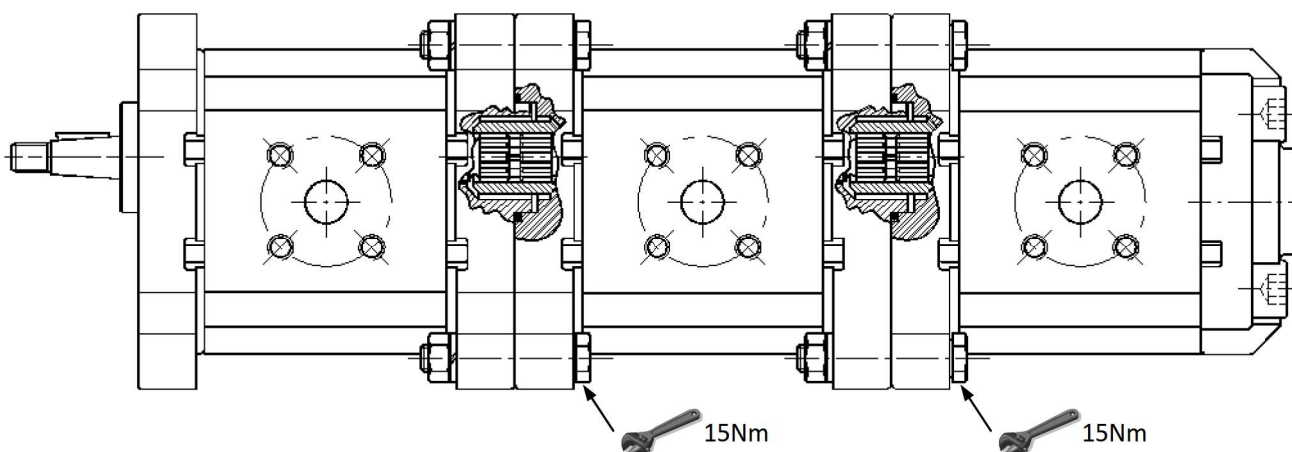

La pressione delle pompe intermedie e posteriori è limitata dalla tenuta del mozzo. La coppia massima è di **27 Nm**.
Max shaft loading must conform to the limitation of coupling.
*Max torque is **27 Nm**.*

Disponibile a richiesta versione con coppia massima fino a 50 Nm, per maggiori informazioni contattare nostro ufficio tecnico.
Shaft with max torque of 50 Nm available on request.
For more info contact our technical office.

KIT FOR 27Nm TYPE	
Ref	PARTI PARTS
1	M6 x 35 UNI 5737
2	OR 2100
3	GS87067
4	Rosetta Ø6 Washer Ø6
5	Dado M6 Stud nut M6
Codice KIT <i>Code KIT</i>	K1000000

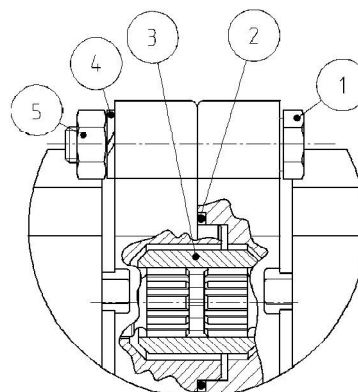

KIT FOR 50Nm TYPE	
Ref	PARTI PARTS
1	M6 x 35 UNI 5737
2	OR 2100
3	GS87161
4	Rosetta Ø6 Washer Ø6
5	Dado M6 Stud nut M6
Codice KIT <i>Code KIT</i>	K1000011

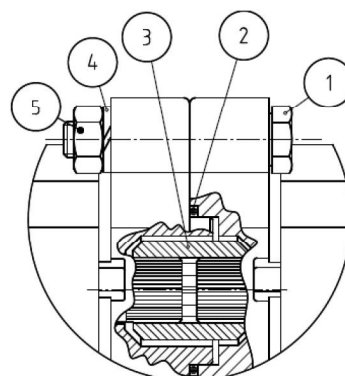

POMPE E MOTORI CON VALVOLA DI MASSIMA PRESSIONE
PUMPS AND MOTORS WITH RELIEF VALVES

VALVOLA A TARATURA REGOLABILE "VR"
VALVE WITH ADJUSTABLE CALIBRATION "VR"

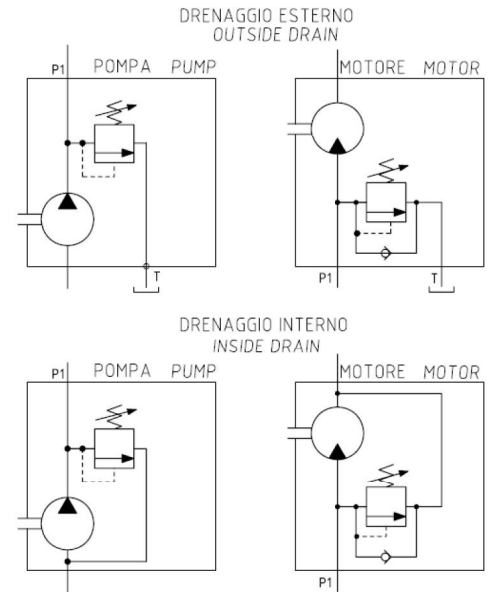
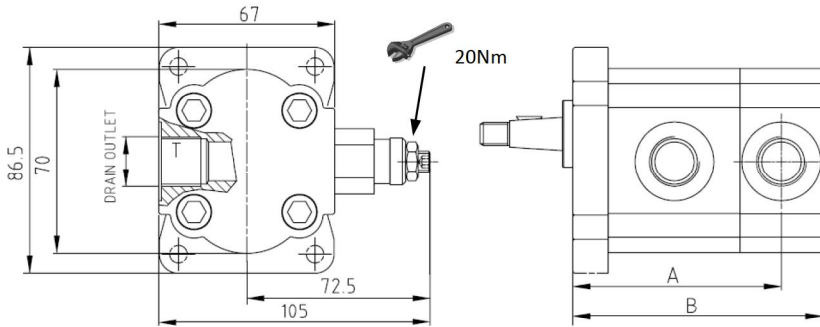

TYPE	8	11	16	21	26	32	37	42	48	55	62	78	88	105
A	72	73	75	77	79	81	83	85	87	90	93	99	103	116
B	87	88	90	92	94	96	98	100	102	105	108	114	118	131

VALVOLA A TARATURA FISSA "VF"
VALVE WITH FIXED CALIBRATION "VF"

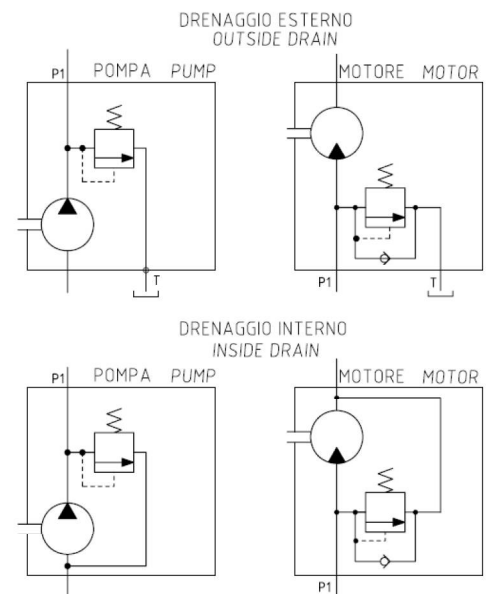
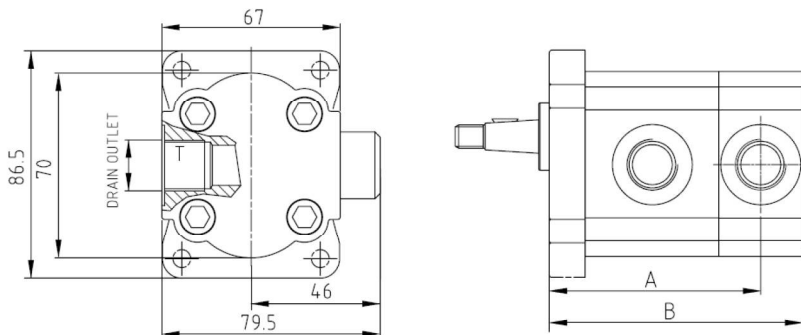

VALORI TARATURA VALVOLA (bar) / CALIBRATION AVAILABLE (bar)
50 - 75 - 100 - 125 - 150 - 200 - 250 - 300 - 330

ISTRUZIONI PER L'ORDINAZIONE DI UNITA' SINGOLE Z1
HOW TO ORDER Z1 SINGLE UNITS

		1	2	3	4	5	6	7	8	9	10	11	12	13
0	1	Z	A	G	21	C	4	08	--	D	R	VR	01	210

1	TIPO UNITA' / UNIT TYPE	CODICE / CODE
	PUMP	Z
	MOTOR	ZM

2-3-6	FLANGIA / FLANGE (PAG. 8-9)	CODICE / CODE
	EUROPEA / EUROPEAN	A 0 4
	TEDESCA / GERMAN	B 0 1
	EUROPEA / EUROPEAN	A G 4
	TEDESCA / GERMAN	B G 1
	TEDESCA / GERMAN	B G 5
	TEDESCA / GERMAN	B G 2
	AMERICANA SAE AA / AMERICAN SAE AA	D G 7
	EUROPEA / EUROPEAN	E G 2
	AMERICANA SAE AA / AMERICAN SAE AA	C G 6
	EUROPEA / EUROPEAN	E 0 2

4	CILINDRATA / CAPACITY cm ³	CODICE / CODE
	0.80	08
	1.08	11
	1.59	16
	2.09	21
	2.59	26
	3.15	32
	3.68	37
	4.19	42
	4.79	48
	5.49	55
	6.2	62
	7.81	78
	8.82	88
	10.5	105

5	ALBERO / SHAFT (PAG. 10-11)	CODICE / CODE
	CONICO 1:8 / TAPERED 1:8	C
	PENNA 11 x 5	F
	PENNA 10 x 5	M
	PENNA CORTO 10 x 5	G
	12x9 Z6 DIN 5487	D
	CONICO 1:5 / TAPERED 1:5	B
	CILINDRICO Ø 12.7 / STRAIGHT Ø 12.7	N
	ANSI B92.1 9TH 20/40 FLAT ROOT	Q
	CILINDRICO Ø 12.7x38 / STRAIGHT Ø 12.7x38	P
	CONICO 1:8 Ø 12.7 / TAPERED 1:8 Ø 12.7	S

	CILINDRICO Ø 12 / STRAIGHT Ø 12	R
	CILINDRICO Ø 10 / STRAIGHT Ø 10	L

7	BOCCHIE / PORTS (PAG.12-13)	CODICE / CODE
	GERMAN	14-28
	EUROPEAN	13-16-17-42
	GAS	00-01-03-04-05-06-08-09-19-20
	SAE	53 - 54

8	PRED. TANDEM / FOR TANDEM	CODICE / CODE
	PREDISPOSTA / FOR TANDEM	T
	NIENTE / NONE	--

9	ROTAZIONE / ROTATION	CODICE / CODE
	DESTRO / RIGHT	D
	SINISTRO / LEFT	S
	BIDIREZIONALE DRENAGGIO ANTERIORE / BIDIRECTIONAL WITH FRONT DRAIN	R1
	BIDIREZIONALE DRENAGGIO POSTERIORE / BIDIRECTIONAL WITH EXTERNAL REAR DRAIN	R
	BIDIREZIONALE DRENAGGIO INTERNO / BIDIRECTIONAL WITH INTERNAL DRAIN	Y

10	PARAOILIO / SHAFT SEAL (PAG.7)	CODICE / CODE
	STANDARD / STANDARD	N
	STANDARD VITON / STANDARD VITON	V
	5 BAR NBR / 5 BAR NBR	R
	5 BAR VITON / 5 BAR VITON	RV
	DOPPIO MIM NBR / DOUBLE SEAL NBR	N2
	DOPPIO MIM VITON / DOUBLE SEAL VITON	V2
	25 BAR VARISEAL NBR / 25 BAR VARISEAL NBR	B
	25 BAR NBR / 25 BAR NBR	BN
	25 BAR VITON / 25 BAR VITON	BV

11	VALVOLA DI MASSIMA / RELIEF VALVE	CODICE / CODE
	SENZA / WITHOUT	-
	TARATURA REGOLABILE / ADJUST. CALIBRATION	VR
	TARATURA FISSA / FIXED CALIBRATION	VF

12	TIPO DRENAGGIO / DRAIN DIMENSION	CODICE / CODE
	1/8" G	1
	7/16" -20 UNF -2B	2

13	VALORI TARATURA VALVOLA	CODICE / CODE
	50 - 75 - 100 - 125 - 150 - 200 - 250 - 300 - 330	

ISTRUZIONI PER L'ORDINAZIONE DI UNITA' MULTIPLE Z1
HOW TO ORDER Z1 MULTIPLE UNITS

			1	2	3	4	5	6	7	8	
0	1	Z	A	G	88	C	4	14	A	S	V

POMPA ANTERIORE
FRONT PUMP

				2	3			6	7	
0	1	Z	A	G	42	0	0	14	I	S

POMPA INTERMEDIA
MIDDLE PUMP

				2	3			6	7	
0	1	Z	A	G	21	0	0	14	P	S

POMPA POSTERIORE
REAR PUMP

1-2-5	FLANGIA / FLANGE (PAG. 8-9)	CODICE / CODE
	EUROPEA / EUROPEAN	A 0 4
	TEDESCA / GERMAN	B 0 1
	EUROPEA / EUROPEAN	A G 4
	TEDESCA / GERMAN	B G 1
	TEDESCA / GERMAN	B G 5
	TEDESCA / GERMAN	B G 2
	AMERICANA SAE AA / AMERICAN SAE AA	D G 7
	EUROPEA / EUROPEAN	E G 2
	AMERICANA SAE AA / AMERICAN SAE AA	C G 6
	EUROPEA / EUROPEAN	E 0 2

	CILINDRICO Ø 12.7 / STRAIGHT Ø 12.7	N
	ANSI B92.1 9TH 20/40 FLAT ROOT	Q
	CILINDRICO Ø 12.7x38 / STRAIGHT Ø 12.7x38	P
	CONICO 1:8 Ø 12.7 / TAPERED 1:8 Ø 12.7	S
	CILINDRICO Ø 12 / STRAIGHT Ø 12	R
	CILINDRICO Ø 10 / STRAIGHT Ø 10	L

3	CILINDRATA / CAPACITY cm ³	CODICE / CODE
	0.80	08
	1.08	11
	1.59	16
	2.09	21
	2.59	26
	3.15	32
	3.68	37
	4.19	42
	4.79	48
	5.49	55
	6.2	62
	7.81	78
	8.82	88
	10.5	105

6	BOCCHIE / PORTS (PAG.12-13)	CODICE / CODE
	GERMAN	14-27-28-29
	EUROPEAN	11-12-13-15-16-17-18-42
	GAS	00-01-02-03-04-05-06-07-08-09-10-19-20-21
	SAE	53 - 54

7	ROTAZIONE / ROTATION	CODICE / CODE
	DESTRO / RIGHT	D
	SINISTRO / LEFT	S

4	ALBERO / SHAFT (PAG. 10-11)	CODICE / CODE
	CONICO 1:8 / TAPERED 1:8	C
	PENNA 11 x 5	F
	PENNA 10 x 5	M
	PENNA CORTO 10 x 5	G
	12x9 Z6 DIN 5487	D
	CONICO 1:5 / TAPERED 1:5	B

8	PARAOILIO / SHAFT SEAL (PAG.7)	CODICE / CODE
	STANDARD / STANDARD	N
	STANDARD VITON / STANDARD VITON	V
	5 BAR NBR / 5 BAR NBR	RB
	5 BAR VITON / 5 BAR VITON	RV
	DOPPIO MIM NBR / DOUBLE SEAL NBR	N2
	DOPPIO MIM VITON / DOUBLE SEAL VITON	V2
	25 BAR VARISEAL NBR / 25 BAR VARISEAL NBR	B
	25 BAR NBR / 25 BAR NBR	BN
	25 BAR VITON / 25 BAR VITON	BV

POMPA MULTIPLA Z1 CON VALVOLA DISGIUNTRICE
MULTIPLE PUMPS Z1 WITH SEQUENCE VALVE (HIGH-LOW PUMP)

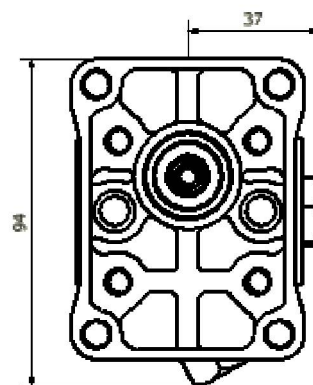
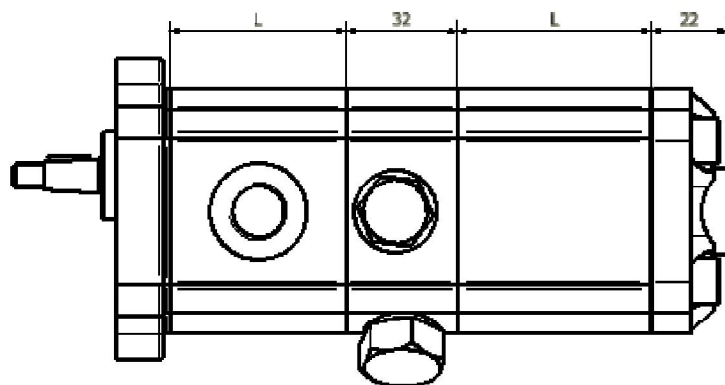
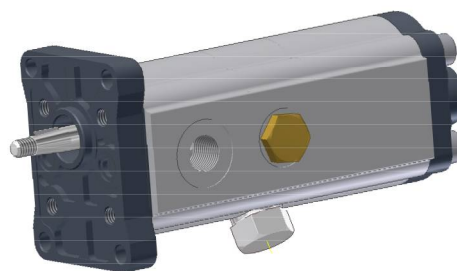
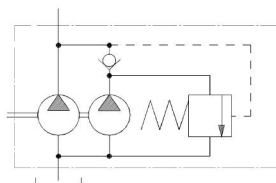

	1	2		3	4	5	6	7	8	9		
0	1	Z	A	0	D	11	48	C	4	01	S	N

1-2-6	FLANGIA / FLANGE (PAG. 8-9)	CODICE / CODE
	EUROPEA / EUROPEAN	A 0 4
	TEDESCA / GERMAN	B 0 1
	EUROPEA / EUROPEAN	A G 4
	TEDESCA / GERMAN	B G 1
	TEDESCA / GERMAN	B G 5
	TEDESCA / GERMAN	B G 2
	AMERICANA SAE AA / AMERICAN SAE AA	D G 7
	EUROPEA / EUROPEAN	E G 2
	AMERICANA SAE AA / AMERICAN SAE AA	C G 6
	EUROPEA / EUROPEAN	E 0 2

3-4	CILINDRATA / CAPACITY cm ³	CODICE / CODE
	0.80	08
	1.08	11
	1.59	16
	2.09	21
	2.59	26
	3.15	32
	3.68	37
	4.19	42
	4.79	48
	5.49	55

5	ALBERO / SHAFT (PAG. 10-11)	CODICE / CODE
	CONICO 1:8 / TAPERED 1:8	C
	12x9 Z6 DIN 5487	D
	CONICO 1:5 / TAPERED 1:5	B

	CILINDRICO Ø 12.7 / STRAIGHT Ø 12.7	N
	ANSI B92.1 9TH 20/40 FLAT ROOT	Q
	CILINDRICO Ø 12.7x38 / STRAIGHT Ø 12.7x38	P
	CONICO 1:8 Ø 12.7 / TAPERED 1:8 Ø 12.7	S
	CILINDRICO Ø 12 / STRAIGHT Ø 12	R
	CILINDRICO Ø 10 / STRAIGHT Ø 10	L

7	BOCCHIE / PORTS (PAG.12-13)	CODICE / CODE
	GERMAN	14-27-28-29
	EUROPEAN	11-12-13-15-16-17-18-42
	GAS	00-01-02-05-06-08-09-10
	SAE	53 - 54

8	ROTAZIONE / ROTATION	CODICE / CODE
	DESTRO / RIGHT	D
	SINISTRO / LEFT	S

9	PARAOILIO / SHAFT SEAL (PAG.7)	CODICE / CODE
	STANDARD / STANDARD	N
	STANDARD VITON / STANDARD VITON	V
	5 BAR NBR / 5 BAR NBR	RB
	5 BAR VITON / 5 BAR VITON	RV
	DOPPIO MIM NBR / DOUBLE SEAL NBR	N2
	DOPPIO MIM VITON / DOUBLE SEAL VITON	V2
	25 BAR VARISEAL NBR / 25 BAR VARISEAL NBR	B
	25 BAR NBR / 25 BAR NBR	BN
	25 BAR VITON / 25 BAR VITON	BV